

Sailing Instructions

UKLA National Championships 2020

ILCA 7 / Standard Rig & ILCA 4 / 4.7 Rig

Sunday 23rd August – Wednesday 26th August 2020

ILCA 6/Radial Rig

Wednesday 26th August – Saturday 29th August 2020

Hosted by Weymouth and Portland National Sailing Academy (WPNSA)

The Organising Authority (OA) is WPNSA in conjunction with the UKLA.

The notation '[DP]' in a rule in the SI means that the penalty for a breach of that rule may, at the discretion of the protest committee (PC), be less than disqualification.

1. RULES

- 1.1 The races will be governed by the rules as defined by The Racing Rules of Sailing, the Notice of Race, the Sailing Instructions and any Appendices.
- 1.2 RRS Appendix T, Arbitration, will apply
- 1.3 Boats shall comply with the ILCA Class Rules. [DP]
- 1.4 RRS Appendix P, Special Procedures for RRS 42, will apply

2. NOTICES TO COMPETITORS

- 2.1 Notices will be posted on the Official Notice Board, which is situated at <https://www.wpnsa.org.uk/events/ukla-nationals-championships-2020>
- 2.2 The race office may be contacted by emailing race.office@wpnsa.org.uk.

3. CHANGES TO SAILING INSTRUCTIONS

Any change to the sailing instructions will be posted not less than 30 minutes before flag D is displayed, except that changes to the schedule of races will be posted before 19.00 on the day before it will take effect.

4. SIGNALS MADE ASHORE

- 4.1 Signals made ashore will be displayed on the flagpoles on the main mast outside the academy
- 4.2 When flag AP is displayed ashore, '1 minute' is replaced with 'not less than 30 minutes' when racing in Portland Harbour or 'not less than 60 minutes' when racing is in Weymouth Bay, in the race signal AP.
- 4.3 Flag D with one sound means 'The warning signal will be made not less than 30 minutes' after flag D is displayed if racing is in Portland Harbour or 'The warning signal will be made not less than 60 minutes' after flag D is displayed if racing is in Weymouth Bay. Boats shall not leave the slipway until this signal is made. [DP].
- 4.4 Flag P displayed indicates racing will be in Portland harbour. Flag W displayed indicates racing will be in Weymouth Bay.

5. SCHEDULE

5.1 The intended schedule is as follows

Date:	Time and location
Sunday 23 rd August	<p>ILCA 7 / Standard Rig & ILCA 4 / 4.7 Rig Competitors arrive after 12:00 Online Registration from 12:00 using the online entry page https://www.kbsuk.com/laser/events/sailorportal.asp Competitors' Briefing online streamed from 18:00 accessed through https://chat.whatsapp.com/ICYvsXyrhYEGl4odKrsxm9</p>
Monday 24 th August	<p>ILCA 7 / Standard Rig & ILCA 4 / 4.7 Rig Online Registration closes 08:45 Morning Briefing streamed 09:00 accessed through https://chat.whatsapp.com/ICYvsXyrhYEGl4odKrsxm9 Intended first warning signal 10:55 Up to 3 Races</p>
Tuesday 25 th August	<p>ILCA 7 / Standard Rig & ILCA 4 / 4.7 Rig Morning Briefing streamed 09:00 accessed through https://chat.whatsapp.com/ICYvsXyrhYEGl4odKrsxm9 Intended first warning signal 10:55 Up to 3 Races</p>
Wednesday 26 th August	<p>ILCA 7 / Standard Rig & ILCA 4 / 4.7 Rig Morning Briefing streamed 08:30 https://chat.whatsapp.com/ICYvsXyrhYEGl4odKrsxm9 Intended first warning signal 09:55 Up to 2 Races Prizegiving will follow racing by invitation. This will be streamed. ILCA 6 / Radial Rig Sailors arrive after 17:00 Online Registration from 15:00 using the online entry page https://www.kbsuk.com/laser/events/sailorportal.asp Competitors' Briefing online streamed from 18:30 accessed through https://chat.whatsapp.com/ICYvsXyrhYEGl4odKrsxm9</p>

Thursday 27 th August	<p>ILCA 6 / Radial Rig Qualifying Series Online Registration closes 08:45 Morning Briefing streamed 09:00 accessed through https://chat.whatsapp.com/ICYvsXyrhYEGl4odKrsxm9 Intended first warning signal 10:55 Up to 3 Races</p>
Friday 28 th August	<p>ILCA 6 / Radial Rig Qualifying Series Morning Briefing streamed 09:00 accessed through https://chat.whatsapp.com/ICYvsXyrhYEGl4odKrsxm9 Intended first warning signal 10:55 Up to 3 Races</p>
Saturday 29 th August	<p>ILCA 6 / Radial Rig Final Series Morning Briefing streamed 08:30 accessed through https://chat.whatsapp.com/ICYvsXyrhYEGl4odKrsxm9 Intended first warning signal 09:55 Up to 2 Races Prizegiving will follow racing by invitation. This will be streamed.</p>



- 5.2 Each day succeeding races will be started as soon as practicable after the finish of the previous race.
- 5.3 No warning signal will be displayed for ILCA 7 / Standard Rig & ILCA 4 / 4.7 Rig after 13:00 on Wednesday 26th August
- 5.4 No warning signal will be displayed for ILCA 6 / Radial Rig after 13:00 on Saturday 29th August.
- 5.5 To alert boats that a race or sequence of races will begin soon, the orange starting line flag will be displayed with one sound signal at least five minutes before a warning signal is made.
- 5.6 The intention is to run up to 8 races for all classes

6. FLEET IDENTIFICATION

- 6.1 While racing each ILCA 6 / Radial Rig in Red fleet or in the final series Silver fleet shall display a Red Ribbon corresponding to her assigned fleet. The Yellow fleet in qualifying and Gold fleet in the final series will have no band. The band (when required) shall be placed on the bottom mast between the boom vang fitting and the boom. [DP]
- 6.2. The coloured bands will be available at sign-out each day and if bands are lost or damaged spares will be available at the slipway. [DP]

7. CLASS FLAG

The class flags for each class will be as follows:

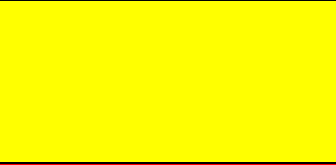
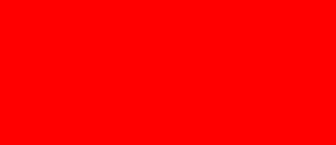
Fleets	Class Flag	Start sequence
<u>ILCA 7 / Standard Rig</u>		First
<u>ILCA 4 / 4.7 Rig</u>		Second
<u>ILCA 6 / Radial Rig (no band)</u> <u>Final series Gold</u>		First
<u>ILCA 6 / Radial Rig (Red band)</u> <u>Final series silver</u>		Second

8. FORMAT OF RACING

- 8.1 It is intended that all classes will sail in a single series of eight (8) races.
- 8.2 ILCA 7 / Standard Rig & ILCA 4 / 4.7 Rig will sail as individual fleets
- 8.3 The ILCA 6 / Radial Rig will be divided into two fleets and will sail a qualifying series of up to six races followed by a final series of two races in accordance with the ILCA Qualifying and Final Series Formats appended to these sailing instructions. Appendix B
- 8.4 ILCA6/ Radial Rig – however many races are completed by the end of the second scheduled racing day the qualifying series will cease. The results at that stage will be used for the assignment of Gold and Silver fleet

9. COURSES

- 9.1 The diagrams in SI Appendix A show the course options to be sailed with the order in which the marks are to be passed and the side on which each mark is to be left.
- 9.2 The course and number of laps to be sailed will be displayed on the Committee Boat.
- 9.3 The approximate bearing of mark 1 may be displayed on the Committee Boat.
- 9.4 If a gate is replaced by a single mark, it is to be left to port.

10. MARKS

- 10.1 Marks 1, 2, 3s, 3p, 4s and 4p will be a 1.6m blue cylindrical buoys with a black band.
- 10.3 The starting mark will be either an official boat with a staff displaying an orange flag or a dan buoy displaying an orange flag
- 10.4 The finishing mark will be either an official boat with a staff displaying a blue flag or a dan buoy displaying a blue flag

11. AREAS THAT ARE OBSTRUCTIONS

- 11.1 Boats shall keep more than 100 metres away from vessels over 100 metres in length, vessels at anchor or vessels displaying Flag A (indicating divers in the water). These areas are obstructions as defined in the Rules.
- 11.2 The attention of all competitors, race management personnel and spectators afloat are drawn to the fact that Portland Harbour is a working port and that harbour regulations must be observed. Any directions given by Portland Harbour Authority either in person or by VHF (CH 74) must be complied with without delay. Failure to comply with this instruction may result in a penalty. [DP].
- 11.3 Boats will not transit at any time through the RNSA moorings, which are to the left of the Marina exit as leaving the Marina.

12. THE START

- 12.1 Races will be started by using RRS 26 with the warning signal made five minutes before the starting signal.
- 12.2 The starting line will be between a staff on the race committee signal vessel displaying an orange flag at the starboard end and the course side of the port end starting mark.
- 12.3 A boat that does not start within four minutes after her starting signal will be scored Did Not Start without a hearing. This changes RRS A4 and A5.

13. CHANGE OF THE NEXT LEG OF THE COURSE

- 13.1 To change the next leg of the course, the race committee will move the original mark (or the finishing line) to a new position.
- 13.2 Minor mark moves, up to approximately 100m, may be made without signalling the change. This changes RRS 33.
- 13.3 Under RRS 32.1, the race committee may abandon the race because of a major wind shift or irregular winds or when the wind speed drops below 5 knots (2.5 m/s) as measured by the race committee. Any action or no action by the race committee under this instruction will not be grounds for redress under RRS 60.1(b)

14. THE FINISH

- 14.1 The finishing line will be between a mast displaying blue flag on the race committee finishing vessel at the starboard end and the course side of the port end finishing mark
- 14.2 The race committee may score boats based on their relative positions at a mark of the course or on a leg of the course as follows:
- 13.2.1 When an official boat displays flag W with two sounds, boats still racing may be scored as their observed position on the race course.
- 13.2.2 When a boat is scored in accordance with this instruction, she shall be given a score for a place after all boats that have sailed the course and finished. This changes RRS A4 and A5.

15. TIME LIMITS

- 15.1 The time limit and target time for the first boat to finish is as follows:
- | Time limit | Target time | Mark 1 Time limit |
|------------|-------------|-------------------|
| 70 minutes | 45 minutes | 20 minutes |
- 15.2 If no boat has passed Mark 1 within the Mark 1 time limit the race will be abandoned. Failure to meet the target time will not be grounds for redress. This changes RRS 62.1(a).
- 15.3 Boats failing to finish within 25 minutes after the first boat in their flight or fleet sails the course and finishes will be scored Did Not Finish. This changes RRS 35, A4 and A5.

16. PENALTIES

- 16.1 RRS Appendix P will apply with the following changes. RRS P2.2 is changed so that it will apply to any penalty after the first one. RRS P2.3 will not apply.
- 16.2 To encourage boats to take a penalty afloat, jury members may blow a whistle when they see what they believe to be a breach of a rule.

17. PROTESTS AND REQUESTS FOR REDRESS

- 17.1 In addition to RRS 61.1(a) a boat intending to protest should notify the committee vessel immediately upon finishing the race or retiring and await acknowledgement.
- 17.2 Protest forms are online at <https://www.wpnas.org.uk/protest-form>. Protests and requests for redress or reopening shall be delivered there within the appropriate time limit using the online form available.
- 17.3 The protest time limit is 60 minutes after the last boat has finished the last race of the day if racing is in Portland Harbour and 90 minutes after the last boat has finished the last race of the day if racing is in Weymouth Bay or 30 minutes after flag AP over A is displayed ashore.
- 17.4 Notices will be posted on the Jury website at <http://laseruknats2020.juryboard.org/> no later than 30 minutes after the protest time limit to inform competitors of hearings in which they are parties or named as witnesses. Hearings will be held online using video links, further instructions are available on the official noticeboard
- 17.5 Notices of protests by the race committee or protest committee will be posted to inform boats under RRS 61.1(b) on the event and Jury websites.
- 17.6 A list of boats that have been penalised for breaking RRS 42 will be posted on the Jury website.
- 17.7 On the last scheduled day of racing, a request for redress based on a PC decision shall be delivered no later than 20 minutes after the decision was posted. This changes RRS 62.2.

18. SCORING

- 18.1 Three races are required to be completed to constitute a championship.
- 18.2 The Low Point System of Appendix A will apply with the following changes:
- 18.3 When fewer than 4 races have been completed, a boats series will be the total of her race scores
- 18.4 When four (4) to eight (8) races have been completed, a boat's series score will be the total of her race scores excluding her worst.
- 18.5 When a qualifying/final series is sailed:
- (a) The qualifying series races and the final series races will count for total points in the championship.
 - (b) A qualifying series race will not count until all qualifying series fleets have completed that race.
 - (c) The worst qualifying series race score will be excluded when calculating the division into final series fleets.
 - (d) If only one final series race is completed it will not be excluded.
 - (e) For the purposes of RRS A4.2 "Scoring" the number of boats entered in a qualifying/final series race will be the number of boats assigned to the largest qualifying fleet.
- 18.6 A competitor may submit a request to review a boat's score online at <https://www.wpnas.org.uk/request-for-a-review-of-a-boats-score>.

19. SAFETY REGULATIONS

- 19.1 Competitors shall wear personal buoyancy at all times whilst afloat, except briefly while adjusting clothing or personal equipment. Flag Y will not be displayed. This changes RRS 40 and Race Signals. [DP]
- 19.2 A safety tally system will be in operation.
- 19.2.1 The tally control point will be by the marquee.
- 19.2.2 A Competitor's tally will be their championship number. Numbers will be allocated and emailed to all competitors ahead of the event.
- 19.2.3 Competitors' shall individually check-out before racing by personally going to the tally control point and giving their championship number to advise they are going racing.
- 19.2.4 Competitors' shall individually check-in immediately on returning to shore by personally going to the tally control point and giving their championship number to advise they are ashore. This must be done no later than 10 minutes after the last boat has come ashore.
- 19.2.5 The penalty for failing to tally-out or tally-in as instructed above will be five points added to the boat's series score for each offence. This changes RRS 63.1 and A5.
- 19.3 A boat that retires from a race shall notify an official boat as soon as possible. A declaration form is available online <https://www.wpnsa.org.uk/retirement-declaration> which must be completed by competitors when ashore.
- 19.4 Boats wishing to sail ashore before the end of the day's racing shall not do so unless authorised by an official boat. The official boat will instruct boats in the procedure for returning ashore. (DP)
- 19.5 Boats shall follow the instructions of the official boats. Infractions will be reported to the RC, which may protest the boat. (DP)

20. REPLACEMENT OF EQUIPMENT

Substitution of damaged or lost equipment will not be allowed unless authorised by the race committee. Requests for substitution of equipment shall be made to the committee at the first reasonable opportunity. A competitor may submit a request online at <https://www.wpnsa.org.uk/request-for-a-change-of-equipment>

21. BERTHING

Boats shall be kept in their assigned place in the dinghy park area whilst ashore. (DP)

22. EQUIPMENT INSPECTIONS

A boat or equipment may be inspected at any time for compliance with the class rules and sailing instructions. On the water or ashore, a boat can be instructed by an equipment inspector to proceed immediately to a designated area for inspection. A boat shall comply with any reasonable request made by an Equipment Inspector. [DP]

23. OFFICIAL BOATS

- 23.1 There will be no support boats at this event, only safety fleet.
- 23.2 Personal equipment such as food bags, drinks, spare parts and extra clothing will not be stored on any official boat for the duration of the event. Competitors should ensure that they carry sufficient food and water on their own boat

24. RADIO COMMUNICATION

A boat that is racing shall not make voice or data transmissions and shall not receive voice or data communications that are not available to all boats. [DP]

25. PRIZES

- 25.1 Prizes will be awarded in accordance with the Notice of Race.
- 25.2 ILCA 7 / Standard Silver division – top 3 places for results purposes only, the ILCA 7 fleet will be subdivided into Gold and Silver divisions, in essentially equal numbers, for the final day of racing. The fleet will continue to race as a single fleet, but at the conclusion of the event, prizes will be awarded to the silver division.
- 25.3 ILCA 4.7 / 4.7 Silver division – 1st Place For results purposes only, the 4.7 fleet will be subdivided into Gold and Silver divisions, in essentially equal numbers, for the final day of racing. The fleet will continue to race as a single fleet, but at the conclusion of the event, a prize will be awarded to the silver division
- 25.4 ILCA 6/ Radial silver fleet – top 3 places will be awarded prizes as described in SI 8.4.

26. RISK STATEMENT AND DISCLAIMER OF LIABILITY

See NOR 20.

27. INSURANCE

See NOR 21.

28. RIGHTS TO USE NAMES AND LIKENESSES

In participating in the event any competitor automatically grants the Organising Authority permission to make, use and show, from time to time, any motion pictures and live, taped or film television and other reproductions of him/her during the period of the event without compensation, in perpetuity. A drone may be flown by a licensed company to record video and still imagery primarily for the event advertising and promotion.

APPENDIX A - THE COURSE DIAGRAMS

O	Outer Trapezoid with finish pin to leeward of finish boat
Signal	Mark Rounding Order
O2	Start-1p-2p-3s/3p-2p-3p-Fin
O3	Start-1p-2p-3s/3p-2p-3s/3p-2p-3p-Fin
O4	Start-1p-2p-3s/3p-2p-3s/3p-2p-3s/3p-2p-3p-Fin

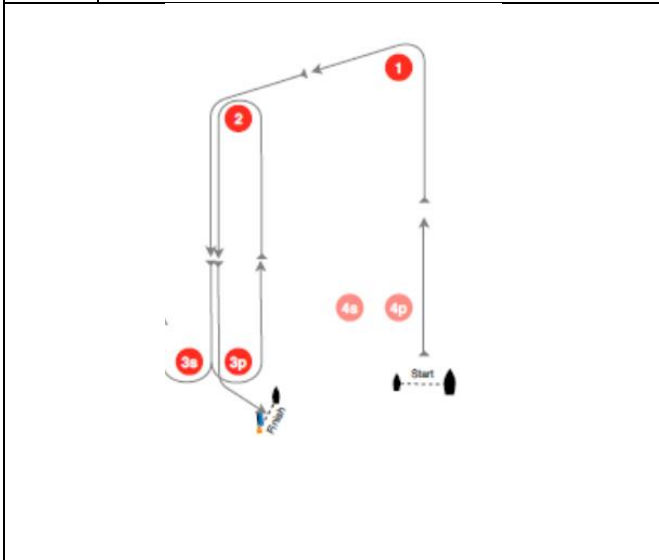

I	Inner Trapezoid with finish pin to leeward of finish boat
Signal	Mark Rounding Order
I2	Start-1p-4s/4p-1p-2p-3p-Fin
I3	Start-1p-4s/4p-1p-4s/4p-1p-2p-3p-Fin
I4	Start-1p-4s/4p-1p-4s/4p-1p-4s/4p-1p-2p-3p-Fin

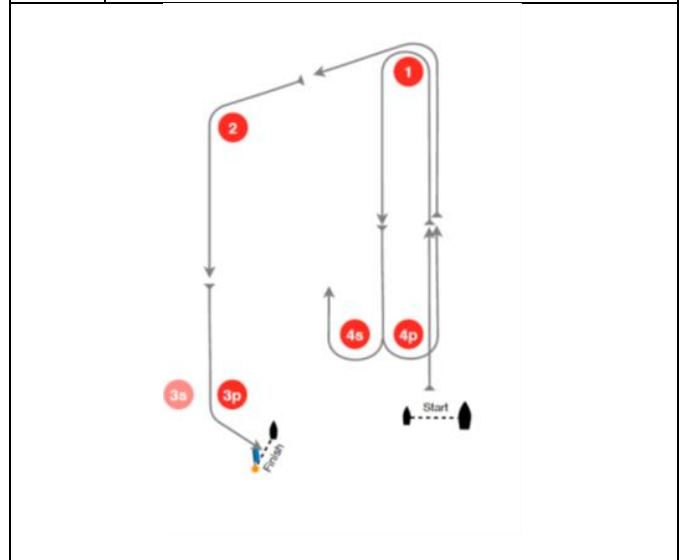

OF	Outer Trapezoid with Finish pin to weather of finish boat
Signal	Mark Rounding Order
OF2	Start-1p-2p-3s/3p-2p-3p-finish
OF3	Start-1p-2p-3s/3p-2p-3s/3p-2p-3p-finish
OF4	Start-1p-2p-3s/3p-2p-3s/3p-2p-3s/3p-2p-3p-finish

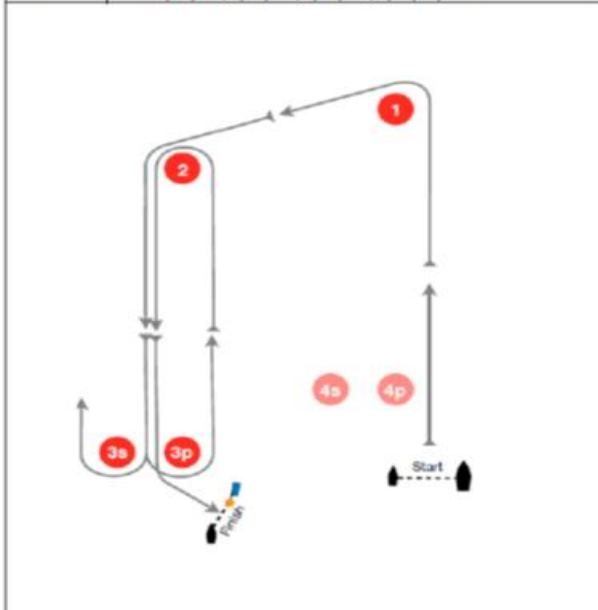

IF	Inner Trapezoid with Finish pin to weather of finish boat
Signal	Mark Rounding Order
IF2	Start-1p-4s/4p-1p-2p-3p-finish
IF3	Start-1p-4s/4p-1p-4s/4p-1p-2p-3p-finish
IF4	Start-1p-4s/4p-1p-4s/4p-1p-4s/4p-1p-2p-3p-finish

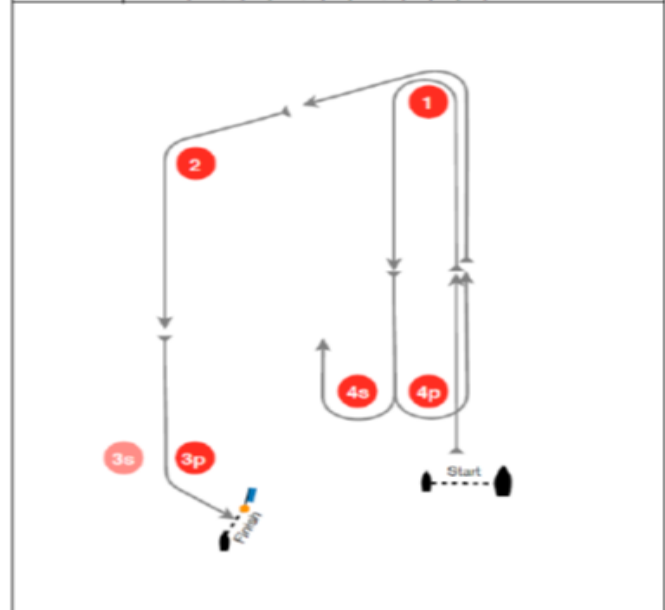

z

L	Inner Trapezoid with finish pin to leeward of finish boat
Signal	Mark Rounding Order
L2	Start-1p-2s/2p-1p-2p-Fin
L3	Start-1p-2s/2p-1p-2s/2p-1p-2p-Fin

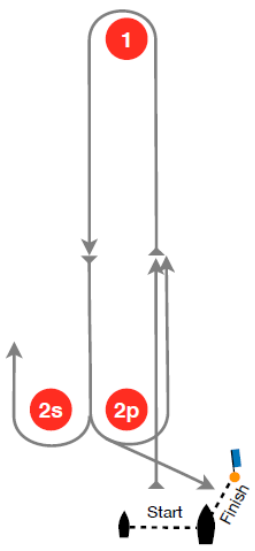

Appendix B

International Laser Class Association Qualifying and Final Series Formats

1. Introduction

1.1 This addendum applies when boats are divided into fleets to sail a qualifying series and a final series.

2. Qualifying Series

- 2.1 For the qualifying series boats that have completed registration will be assigned to fleets of, as near as possible, equal size and ability.
- 2.2 Initial assignments will be made by a seeding committee appointed by the organizing authority and will be posted by 0900 on the last day of registration.
- 2.4 In the qualifying series boats will be reassigned to fleets after each day of racing, except if on the first day only one race is completed. If all fleets have completed the same number of races, boats will be reassigned on the basis of their ranks in the series. If all fleets have not completed the same number of races the series scores for reassignment will be calculated for those races, numbered in order of completion, completed by all fleets.
- 2.5 Reassignments will be made as follows: Two fleet format

Rank in series	Fleet assignment
1	1
2	2
3	2
4	1
5	1
6	2
7	2
8	1
9	1
And so on	And so on

- 2.6 Reassignments will be based on the ranking available at 19:00 that day regardless of protests or requests for redress not yet decided.
- 2.7 A qualifying series race will not count until all qualifying series fleets have completed that race.
- 2.8 The fleets will be reseeded each evening, based upon the completed races. The qualifying series will end after the final race is finished on Friday 28th August irrespective of the number of races completed.
- 2.9 If at the end of the qualifying series some qualifying series fleets have more race scores than others, any extra races will be abandoned so that all boats in the qualifying series have the same number of race scores.

3. Final Series

- 3.1 Boats will be assigned to final series fleets on the basis of their ranks in the qualifying series.
- 3.2 There will be the same number of fleets in the final series as there were in the qualifying series.
- 3.3 The final series fleets will be, as nearly as possible, of equal size but so that the Silver fleet is not larger than the Gold fleet. Boats with the best qualifying series ranks will race all final series races in the Gold fleet; boats with the next best qualifying series ranks will race in the Silver fleet.
- 3.4 Any recalculation of qualifying series ranking after boats have been assigned to final series fleets will not affect the assignments except that a redress decision may promote a boat to a higher fleet.
- 3.5 Different final series fleets need not have completed the same number of final races. The boats in the Gold fleet will be ranked highest, except for a boat disqualified from a final series race under RRS 5, 6, 7 or 69.